

# Hardware design with RP2040

Using RP2040 microcontrollers  
to build boards and products

# Colophon

Copyright © 2020-2024 Raspberry Pi Ltd (formerly Raspberry Pi (Trading) Ltd.)

The documentation of the RP2040 microcontroller is licensed under a Creative Commons [Attribution-NoDerivatives 4.0 International](#) (CC BY-ND).

build-date: 2024-02-02

build-version: 169135e-dirty

## About the SDK

Throughout the text "the SDK" refers to our [Raspberry Pi Pico SDK](#). More details about the SDK can be found in the [Raspberry Pi Pico C/C++ SDK](#) book. Source code included in the documentation is Copyright © 2020-2023 Raspberry Pi Ltd (formerly Raspberry Pi (Trading) Ltd.) and licensed under the [3-Clause BSD](#) license.

## Legal disclaimer notice

TECHNICAL AND RELIABILITY DATA FOR RASPBERRY PI PRODUCTS (INCLUDING DATASHEETS) AS MODIFIED FROM TIME TO TIME ("RESOURCES") ARE PROVIDED BY RASPBERRY PI LTD ("RPL") "AS IS" AND ANY EXPRESS OR IMPLIED WARRANTIES, INCLUDING, BUT NOT LIMITED TO, THE IMPLIED WARRANTIES OF MERCHANTABILITY AND FITNESS FOR A PARTICULAR PURPOSE ARE DISCLAIMED. TO THE MAXIMUM EXTENT PERMITTED BY APPLICABLE LAW IN NO EVENT SHALL RPL BE LIABLE FOR ANY DIRECT, INDIRECT, INCIDENTAL, SPECIAL, EXEMPLARY, OR CONSEQUENTIAL DAMAGES (INCLUDING, BUT NOT LIMITED TO, PROCUREMENT OF SUBSTITUTE GOODS OR SERVICES; LOSS OF USE, DATA, OR PROFITS; OR BUSINESS INTERRUPTION) HOWEVER CAUSED AND ON ANY THEORY OF LIABILITY, WHETHER IN CONTRACT, STRICT LIABILITY, OR TORT (INCLUDING NEGLIGENCE OR OTHERWISE) ARISING IN ANY WAY OUT OF THE USE OF THE RESOURCES, EVEN IF ADVISED OF THE POSSIBILITY OF SUCH DAMAGE.

RPL reserves the right to make any enhancements, improvements, corrections or any other modifications to the RESOURCES or any products described in them at any time and without further notice.

The RESOURCES are intended for skilled users with suitable levels of design knowledge. Users are solely responsible for their selection and use of the RESOURCES and any application of the products described in them. User agrees to indemnify and hold RPL harmless against all liabilities, costs, damages or other losses arising out of their use of the RESOURCES.

RPL grants users permission to use the RESOURCES solely in conjunction with the Raspberry Pi products. All other use of the RESOURCES is prohibited. No licence is granted to any other RPL or other third party intellectual property right.

HIGH RISK ACTIVITIES. Raspberry Pi products are not designed, manufactured or intended for use in hazardous environments requiring fail safe performance, such as in the operation of nuclear facilities, aircraft navigation or communication systems, air traffic control, weapons systems or safety-critical applications (including life support systems and other medical devices), in which the failure of the products could lead directly to death, personal injury or severe physical or environmental damage ("High Risk Activities"). RPL specifically disclaims any express or implied warranty of fitness for High Risk Activities and accepts no liability for use or inclusions of Raspberry Pi products in High Risk Activities.

Raspberry Pi products are provided subject to RPL's [Standard Terms](#). RPL's provision of the RESOURCES does not expand or otherwise modify RPL's [Standard Terms](#) including but not limited to the disclaimers and warranties expressed in them.

# Table of contents

Colophon .....	1
Legal disclaimer notice .....	1
1. About the RP2040 .....	3
2. Minimal design example .....	5
2.1. Power .....	6
2.1.1. Input supply .....	6
2.1.2. Decoupling capacitors .....	7
2.1.3. Internal voltage regulator .....	7
2.2. Flash storage .....	8
2.3. Crystal oscillator .....	9
2.3.1. Recommended crystal .....	10
2.4. I/Os .....	10
2.4.1. USB .....	10
2.4.2. I/O headers .....	11
2.5. Schematic .....	12
2.6. Supported flash chips .....	12
2.7. Making a PCB .....	13
3. The VGA, SD card & audio demo boards for Raspberry Pi Pico and Raspberry Pi Pico W .....	14
3.1. Power .....	15
3.1.1. Power input .....	15
3.1.2. Audio power supply .....	18
3.2. VGA video .....	18
3.2.1. Resistor DAC .....	19
3.2.2. User buttons .....	20
3.3. SD card .....	21
3.3.1. UART .....	21
3.3.2. Debug – SWD .....	22
3.4. Audio .....	22
3.4.1. PWM audio .....	22
3.4.2. PCM/I2S audio .....	23
3.5. Raspberry Pi Pico and Raspberry Pi Pico W .....	23
3.6. Schematics .....	27
Appendix A: Using the rescue debug port .....	30
Overview .....	30
Activating the rescue DP from OpenOCD .....	30
Appendix B: Documentation release history .....	32

# Chapter 1. About the RP2040

RP2040 is a low-cost, high-performance microcontroller device with flexible digital interfaces. Key features:

- Dual Cortex M0+ processors, up to 133MHz
- 264kB of embedded SRAM in 6 banks
- 30 multifunction GPIO
- 6 dedicated I/O for SPI flash (supporting XIP)
- Dedicated hardware for commonly used peripherals
- Programmable I/O for extended peripheral support
- 4 channel ADC with internal temperature sensor, 500kps, 12-bit conversion
- USB 1.1 host/device

Figure 1. A system overview of the RP2040 chip

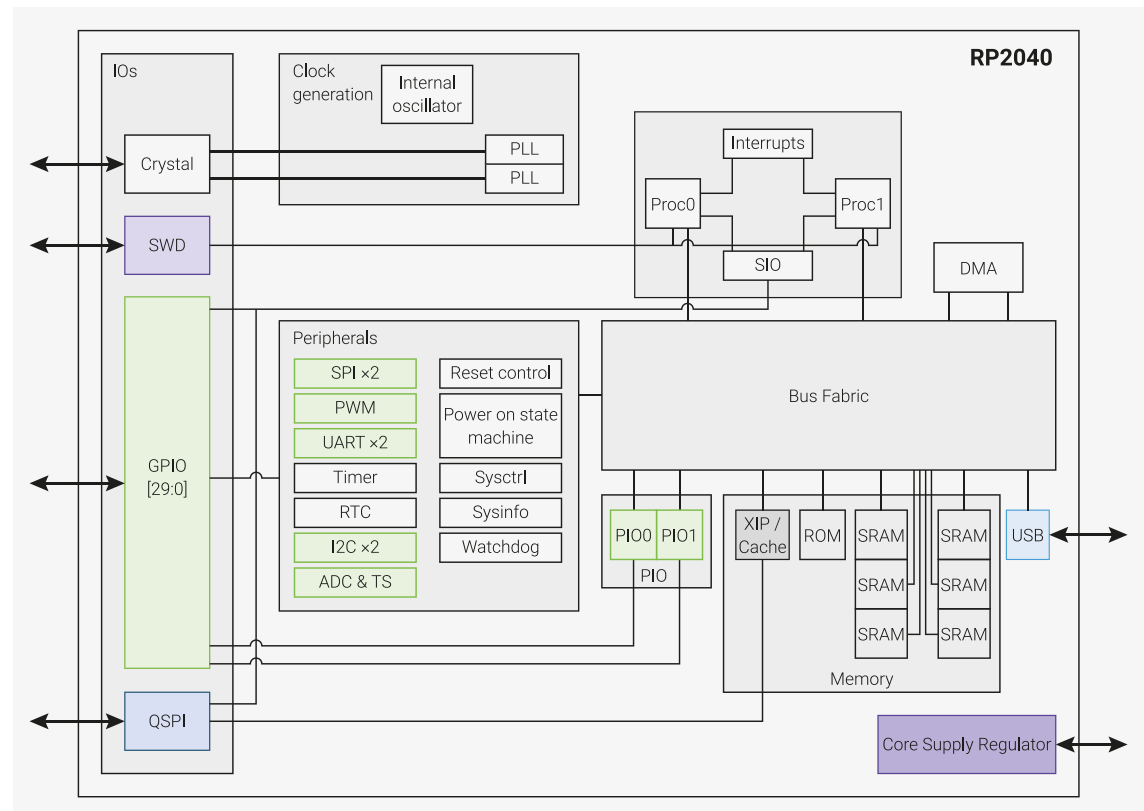

Code may be executed directly from external memory, through a dedicated SPI, DSPI or QSPI interface. A small cache improves performance for typical applications.

Debug is available via the SWD interface.

Internal SRAM is arranged in banks which can contain code or data and is accessed via dedicated AHB bus fabric connections, allowing bus masters to access separate bus slaves without being stalled.

DMA bus masters are available to offload repetitive data transfer tasks from the processors.

GPIO pins can be driven directly, or from a variety of dedicated logic functions.

Dedicated peripheral IP provides fixed functions such as SPI, I2C, UART.

Flexible configurable PIO controllers can be used to provide a wide variety of I/O functions.

A simple USB controller with embedded PHY can be used to provide FS/LS host or device connectivity under software



control.

4 GPIOs also share package pins with ADC inputs.

2 PLLs are available to provide a USB or ADC fixed 48MHz clock, and a flexible system clock up to 133MHz

An internal voltage regulator will supply the core voltage so the end product only needs supply the I/O voltage.

## Chapter 2. Minimal design example

Figure 2. KiCad 3D rendering of the minimal design example

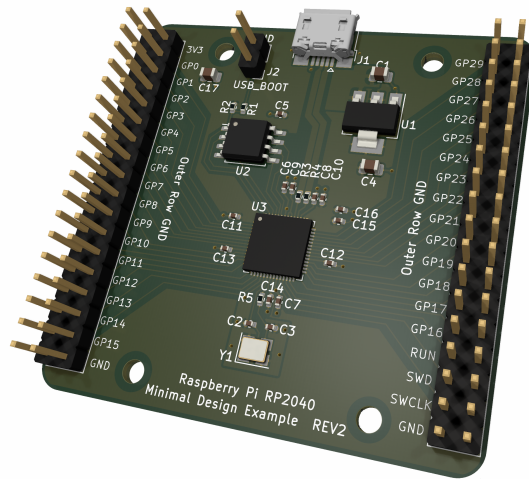

This minimal design example is intended to demonstrate how you can get started with your own RP2040 based PCB designs. It consists of very nearly the minimum amount of circuitry required to make a functional design that can run your code. Schematics and layout files are available for KiCad at <https://datasheets.raspberrypi.com/rp2040/Minimal-KiCAD.zip>. KiCad is a free, open source suite of tools for designing PCBs and can be found at <https://kicad.org/>.

This example PCB has two copper layers, and has components on the top side only (this makes it cheaper and easier to assemble). It also uses small SMD (surface-mount devices) components. The relatively large minimum track width, clearances and hole sizes should make this design easily and cheaply manufacturable from a range of PCB suppliers. The board is nominally 1mm thick, but it could be manufactured with a thicker PCB, for example 1.6mm is very common, but you might run into difficulties with the USB characteristic impedance (discussed below).

Whilst it might be seen as beneficial to use large, easily hand-solderable components for such an example design, the reality is that RP2040 is a 56 pin, 7x7mm QFN (Quad Flat No-leads) package with a small pitch (0.4mm pin-to-pin spacing). This requires a considerable amount of skill and experience to hand solder successfully. We therefore consider it best to have the PCBs machine assembled, however, if you are able to wield a soldering iron deftly enough to solder a QFN package successfully, then the use of other small SMD components (such as 0402 capacitors) should present few problems.

Figure 3. Schematic section RP2040 connections

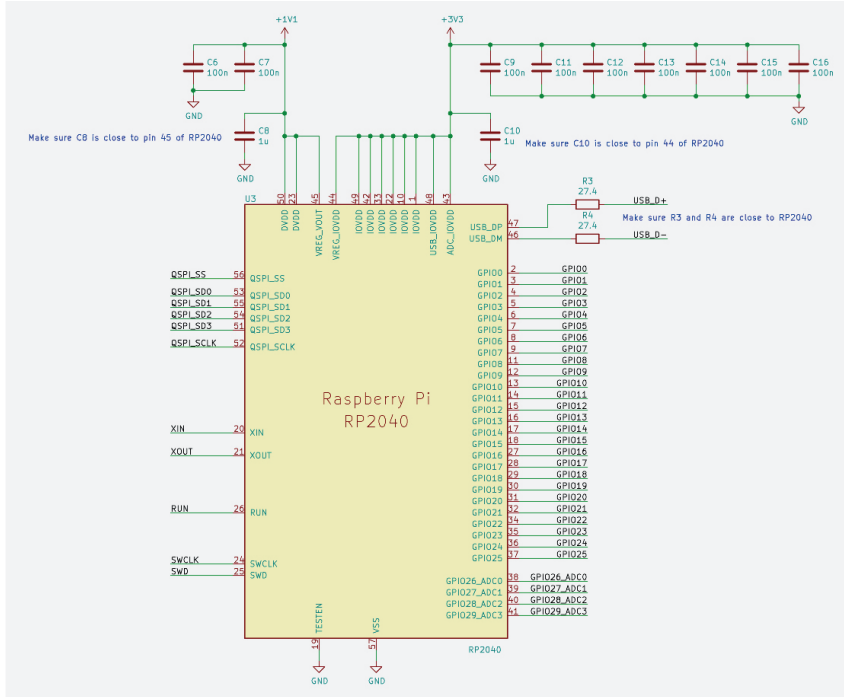

This design consists of four main elements: **power, flash storage, crystal oscillator, and I/Os (input/outputs)**, and we'll consider each in turn below.

## 2.1. Power

At its simplest, RP2040 requires two different voltage supplies, **3.3V** (for the I/O) and **1.1V** (for the chip's digital core). Fortunately, there is an *internal low-dropout voltage regulator (LDO)* built into the device, which converts 3.3V to 1.1V for us, so we don't have to worry too much about the 1.1V supply.

### 2.1.1. Input supply

Figure 4. Schematic section showing the power input

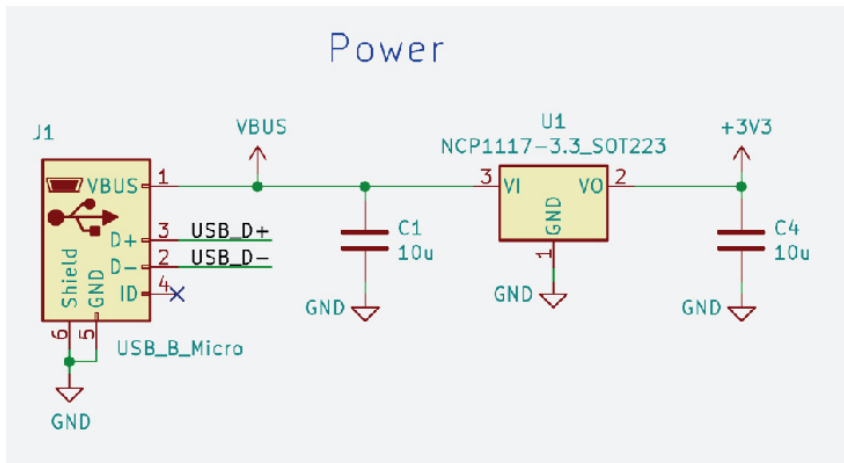

The input power connection for this design is via the 5V VBUS pin of a Micro-USB connector (labelled **J1** in Figure 4). This is a common method of powering electronic devices, and it makes sense here, as RP2040 has USB functionality, which we will be wiring to the data pins of this connector. As we need only 3.3V for this design, we need to lower the incoming 5V USB supply, in this case, using a second, *external LDO voltage regulator*. The *NCP1117 (U1)* chosen here has a fixed output of 3.3V, is widely available, and can provide up to 1A of current, which will be plenty for most designs.

A look at the datasheet for the NCP1117 tells us that this device requires a **10 $\mu$ F** capacitor on the input, and another on the output (**C1** and **C4**).

### 2.1.2. Decoupling capacitors

Figure 5. Schematic section showing the RP2040 power supply inputs, voltage regulator and decoupling capacitors

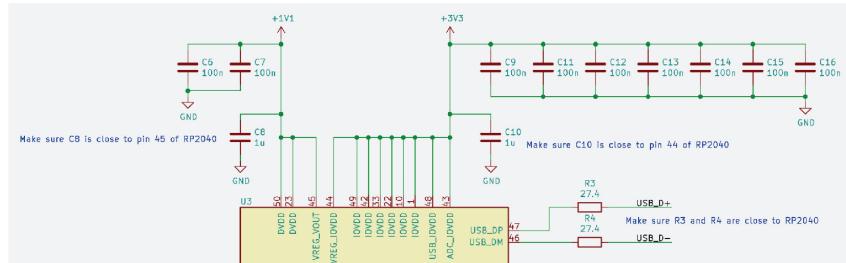

Another aspect of the power supply design are the decoupling capacitors required for RP2040. These provide two basic functions. Firstly, they filter out power supply noise, and secondly, provide a local supply of charge that the circuits inside RP2040 can use at short notice. This prevents the voltage level in the immediate vicinity from dropping too much when the current demand suddenly increases. Because, of this, it is **important to place decoupling close to the power pins**. Ordinarily, we recommend the use of a **100nF capacitor per power pin**, however, we deviate from this rule in a couple of instances.

Figure 6. Section of layout showing RP2040 routing and decoupling

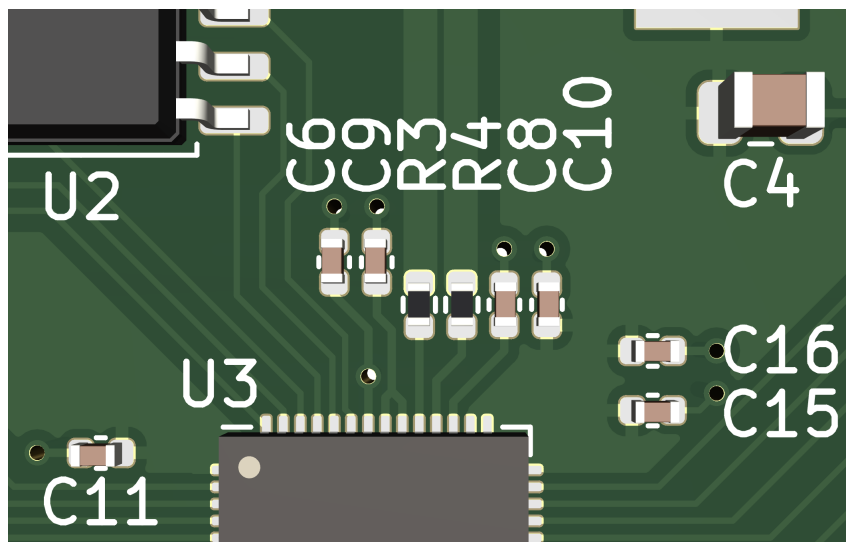

Firstly, in order to be able to have enough space for all of the chip pins to be able to be routed out, away from the device, we have to compromise with the amount of decoupling capacitors we can use. In this design, pins 48 and 49 of RP2040 share a single capacitor (**C9** in [Figure 6](#) and [Figure 5](#)), as there is not a lot of room on that side of the device. This could be overcome if we used more complex/expensive technology, such as smaller components, or a four layer PCB with components on both the top and bottom sides. *This is a design trade-off*; we have decreased the complexity and cost, at the expense of having less decoupling capacitance, and capacitors which are slightly further away from the chip than is optimal (this increases the inductance). This could have the effect of limiting the maximum speed the design could operate at, as the voltage supply could get too noisy and drop below the minimum allowed voltage; but for most applications, this trade-off should be acceptable.

Secondly, the internal voltage regulator has its own special requirements, as you can see below.

### 2.1.3. Internal voltage regulator

The internal voltage regulator produces a 1.1V supply from an input of 3.3V. We simply connect the VREG\_OUT pin to the DVDD pins. The regulator does have some special requirements when it comes to decoupling capacitors. **We must**

place **1 $\mu$ F capacitors close to both the input (VREG\_IN) and the output (VREG\_OUT)**, in order to provide a stable 1.1V supply. The voltage regulator also has restrictions on the amount of ESR (equivalent series resistance) of these capacitors, but in practice, by using physically small ceramic chip capacitors, these requirements will almost certainly be met. In this design, capacitors **C8** and **C10** (Figure 5) are ceramic capacitors of 0402 size.

For more details on the on-chip voltage regulator see [on-chip voltage regulator](#)

## 2.2. Flash storage

Figure 7. Schematic section showing the flash memory and USB\_BOOT circuitry

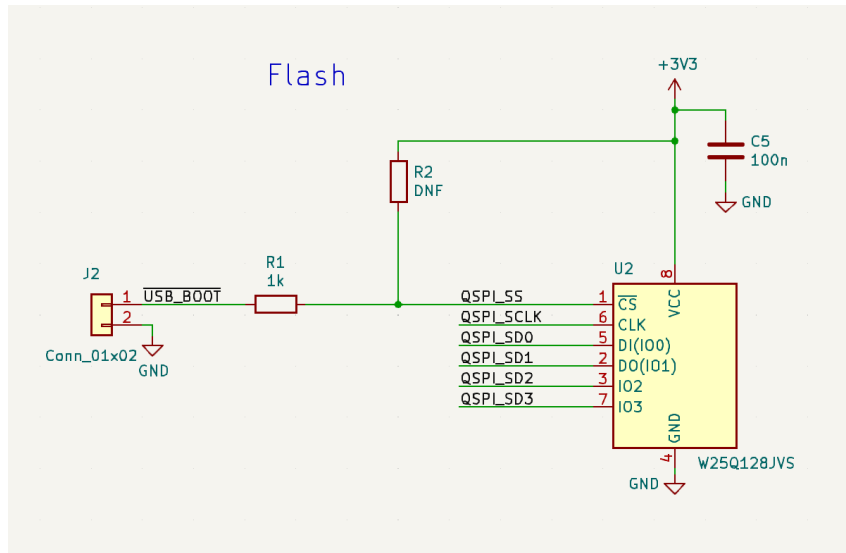

In order to be able to store program code which RP2040 can boot and run from, we need to use a flash memory, specifically, a quad SPI flash memory. The device chosen here is an *W25Q128JVS* device (**U2** in Figure 7), which is a 128Mbit chip (16MB). This is the largest memory size that RP2040 can support. If your particular application doesn't need as much storage, then a smaller, cheaper memory could be used instead.

For more details on selecting a flash device, see [Section 4.10 in the RP2040 Datasheet](#).

As this databus can be quite high frequency and is regularly in use, the **QSPI pins of RP2040 should be wired directly to the flash, using short connections** to maintain the signal integrity, and to also reduce crosstalk in surrounding circuits. Crosstalk is where signals on one circuit net can induce unwanted voltages on a neighbouring circuit, potentially causing errors to occur.

The **QSPI\_SS signal is a special case**. It is connected to the flash directly, but it also has two resistors connected to it. The first (**R2**) is a pull-up to the 3.3V supply. The flash memory requires the chip-select input to be at the same voltage as its own 3.3V supply pin as the device is powered up, otherwise, it does not function correctly. When the RP2040 is powered up, its QSPI\_SS pin will automatically default to a pull-up, but there is a short period of time during switch-on where the state of the QSPI\_SS pin cannot be guaranteed. The addition of a pull-up resistor ensures that this requirement will always be satisfied. **R2** is marked as *DNF* (Do Not Fit) on the schematic, as we have found that with this particular flash device, the external pull-up is unnecessary. However, if a different flash is used, it may become important to be able to insert a **10k $\Omega$**  resistor here, so it has been included just in case. The second resistor (**R1**) is a **1k $\Omega$**  resistor, connected to a header (**J2**) labelled 'USB\_BOOT'. This is because the QSPI\_SS pin is used as a 'boot strap'; RP2040 checks the value of this I/O during the boot sequence, and if it is found to be a logic 0, then RP2040 reverts to the BOOTSEL mode, where RP2040 presents itself as a USB mass storage device, and code can be copied directly to it. If we simply place a jumper wire between the pins of **J2**, we pull QSPI\_SS pin to ground, and if the device is then subsequently reset (e.g. by toggling the RUN pin), RP2040 will restart in BOOTSEL mode instead of attempting to run the contents of the flash.

Both **R1** and **R2** should be placed close to the flash chip, so we avoid additional lengths of copper tracks which could affect the signal.

## 2.3. Crystal oscillator

Figure 8. Schematic section showing the crystal oscillator and load capacitors

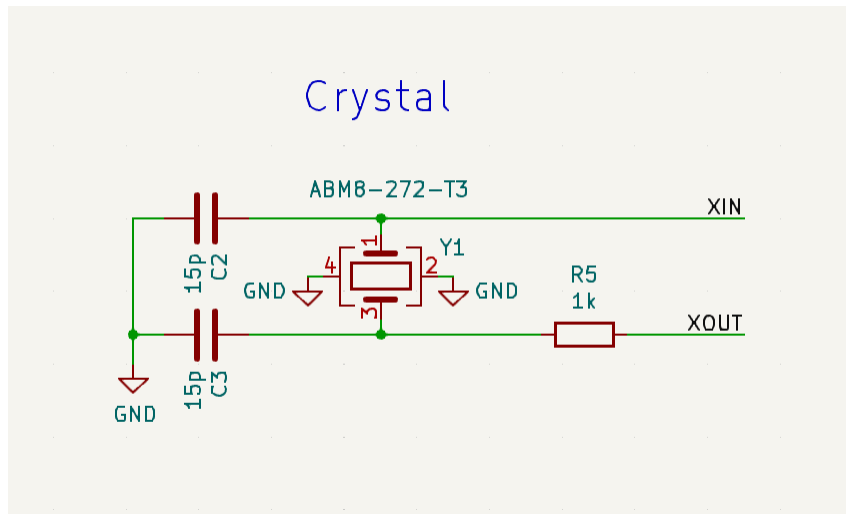

Strictly speaking, RP2040 does not actually require an external clock source, as it has its own internal oscillator. However, as the frequency of this internal oscillator is not well defined or controlled, varying from chip to chip, as well as with different supply voltages and temperatures, it is recommended to use a stable external frequency source. Applications which rely on exact frequencies are not possible without an external frequency source, USB being a prime example.

Providing an external frequency source can be done in one of two ways: either by providing a **clock source with a CMOS output** (square wave of IOVDD voltage) into the XIN pin, or by using a **12MHz crystal** connected between XIN and XOUT. Using a crystal is the preferred option here, as they are both relatively cheap and very accurate.

The chosen crystal for this design is an *ABM8-272-T3* (Y1 in Figure 8). This is the same 12MHz crystal used on the Raspberry Pi Pico. We highly recommend using this crystal along with the accompanying circuitry to ensure that the clock starts quickly under all conditions without damaging the crystal itself. The crystal has a 30ppm frequency tolerance, which should be good enough for most applications. Along with a frequency tolerance of +/-30ppm, it has a maximum ESR of **50Ω**, and a load capacitance of **10pF**, both of which had a bearing on the choice of accompanying components.

For a crystal to oscillate at the desired frequency, the manufacturer specifies the *load capacitance* that it needs for it to do so, and in this case, it is **10pF**. This load capacitance is achieved by placing two capacitors of equal value, one on each side of the crystal to ground (C2 and C3). From the crystal's point of view, these capacitors are connected in *series* between its two terminals. Basic circuit theory tells us that they combine to give a capacitance of  $(C2 \cdot C3) / (C2 + C3)$ , and as  $C2 = C3$ , then it is simply  $C2/2$ . In this example, we've used **15pF** capacitors, so the series combination is **7.5pF**. In addition to this intentional load capacitance, we must also add a value for the unintentional extra capacitance, or parasitic capacitance, that we get from the PCB tracks and the XIN and XOUT pins of RP2040. We'll assume a value of **3pF** for this, and as this capacitance is in *parallel* to C2 and C3, we simply add this to give us a *total load capacitance* of **10.5pF**, which is close enough to the target of **10pF**. As you can see, the parasitic capacitance of the PCB traces are a factor, and we therefore need to keep them small so we don't upset the crystal and stop it oscillating as intended. Try and keep the layout as short as possible.

The second consideration is the *maximum ESR* (equivalent series resistance) of the crystal. We've opted for a device with a maximum of **50Ω**, as we've found that this, along with a **1kΩ** series resistor (R5), is a good value to prevent the crystal being over-driven and being damaged **when using an IOVDD level of 3.3V**. However, if IOVDD is less than 3.3V, then the drive current of the XIN/XOUT pins is reduced, and you will find that the amplitude of the crystal is lower, or may not even oscillate at all. In this case, a smaller value of the series resistor will need to be used. *Any deviation from the crystal circuit shown here, or with an IOVDD level other than 3.3V, will require extensive testing to ensure that the crystal oscillates under all conditions, and starts-up sufficiently quickly as not to cause problems with your application.*

### 2.3.1. Recommended crystal

For original designs using RP2040 we recommend using the Abracon ABM8-272-T3. For example, in addition to the minimal design example, see the Pico board schematic in [Appendix B of the Pico Datasheet](#) and the [Pico design files](#).

For the best performance and stability across typical operating temperature ranges, use the Abracon ABM8-272-T3. You can source the ABM8-272-T3 directly from Abracon or from an authorised reseller. Pico has been specifically tuned for the ABM8-272-T3, which has the following specifications:

Table 1. Key Crystal Specifications.

Parameters	Minimum	Typical	Maximum	Units	Notes
Center Frequency	12.000	12.000	12.000	MHz	
Operation Mode	Fundamental-AT	Fundamental-AT	Fundamental-AT		
Operating Temperature	-40		+85	°C	
Storage Temperature	-55		+125	°C	
Frequency Tolerance (25°C)	-30		+30	ppm	
Frequency Stability (25°C)	-30		+30	ppm	
Equivalent Series Resistance (R1)			50	Ω	
Shunt Capacitance (C0)			3.0	pF	
Load Capacitance (CL)	10	10	10	pF	
Drive Level		10	200	μW	
Aging	-5		+5	ppm	@25±3°C, 1st year
Insulation Resistance	500			MΩ	@100Vdc±15V

Even if you use a crystal with similar specifications, you will need to test the circuit over a range of temperatures to ensure stability.

The crystal oscillator is powered from the VDDIO voltage. As a result, the Abracon crystal and that particular damping resistor are tuned for 3.3V operation. If you use a different IO voltage, you will need to re-tune.

Any changes to crystal parameters risk instability across any components connected to the crystal circuit.

If you can't source the recommended crystal directly from Abracon or a reseller, contact [applications@raspberrypi.com](mailto:applications@raspberrypi.com).

## 2.4. I/Os

### 2.4.1. USB

Figure 9. Schematic section showing the USB pins of RP2040 and series termination

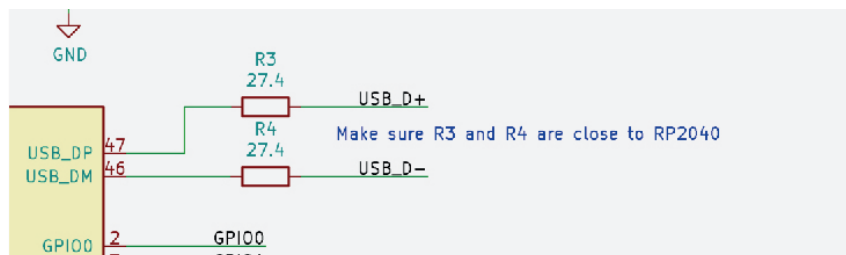

The RP2040 provides two pins to be used for *full speed* (FS) or *low speed* (LS) USB, either as a *host* or *device*, depending on the software used. As we've already discussed, RP2040 can also boot as a USB mass storage device, so wiring up these pins to the USB connector (**J1** in [Figure 4](#)) makes sense. The USB\_DP and USB\_DM pins on RP2040 do not require

any additional pull-ups or pull-downs (required to indicate speed, FS or LS, or whether it is a host or device), as these are built in to the I/Os. However, these I/Os do **require 27Ω series termination resistors (R3 and R4 in Figure 9), placed close to the chip**, in order to meet the USB impedance specification.

Even though RP2040 is limited to full speed data rate (12Mbps), we should try and makes sure that the *characteristic impedance* of the transmission lines (the copper tracks connecting the chip to the connector) are close to the USB specification of **90Ω** (measured differentially). On a **1mm** thick board such as this, if we use **0.8mm** wide tracks on USB\_DP and USB\_DM, with a gap of **0.15mm** between them, we should get a differential characteristic impedance of around **90Ω**. This is to ensure that the signals can travel along these transmission lines as cleanly as possible, minimising voltage reflections which can reduce the integrity of the signal. In order for these transmission lines to work properly, we *need to make sure that directly below these lines is a ground*. A solid, uninterrupted area of ground copper, stretching the entire length of the track. On this design, almost the entirety of the bottom copper layer is devoted to ground, and particular care was taken to ensure that the USB tracks pass over nothing but ground. If a PCB *thicker than 1mm* is chosen for your build, then we have two options. We could re-engineer the USB transmission lines to compensate for the greater distance between the track and ground underneath (which could be a physical impossibility), or we could ignore it, and hope for the best. USB FS can be quite forgiving, but your mileage may vary. It is likely to work in many applications, but it's probably not going to be compliant to the USB standard.

### 2.4.2. I/O headers

Figure 10. Schematic section showing the 2.54mm I/O headers



In addition to the USB connector already mentioned, there are a pair of 2×18-way 2.54mm headers (J3 and J4 in Figure 10), one on each side of the board, to which the rest of the I/O have been connected. As this is a general purpose design, with no particular application in mind, the I/O have been made available to be connected as the user wishes. The inner row of pins on each header are the I/Os, and the outer row are all connected to ground. It is good practice to include many grounds on I/O connectors. This helps to maintain a low impedance ground, and also to provide plenty of potential return paths for currents travelling to and from the I/O connections. This is important to minimise electromagnetic interference which can be caused by the return currents of quickly switching signals taking long, looping paths to complete the circuit.

Both headers are on the same 2.54mm grid, which makes connecting this board to other things, such as breadboards, easier. You might want to consider fitting only a single row 18-way header instead of the 2×18-way, dispensing with the outer row of ground connections, to make it more convenient to fit to a breadboard.





discontinuing XIP on a range of flash devices:

- `CSn=1, IO[3:0]=4'b0000` (via pull downs to avoid contention), issue  $\times 32$  clocks
- `CSn=0, IO[3:0]=4'b1111` (via pull ups to avoid contention), issue  $\times 32$  clocks
- `CSn=1`
- `CSn=0, MOSI=1'b1` (driven low-Z, all other I/Os Hi-Z), issue  $\times 16$  clocks

If your chosen device does not respond to this sequence when in its continuous read mode, then it must be kept in a state where each transfer is prefixed by a serial command, otherwise RP2040 will not be able to recover following an internal reset.

## 2.7. Making a PCB

The minimal design example, see [Chapter 2](#), was deliberately designed with two copper layers, and with components on the top side only. The design rules are relaxed, to allow low cost PCB fabrication. This particular design has been verified to work with Eurocircuits (<https://www.eurocircuits.com/>) standard PCB pool, though there should be few problems having it manufactured by other PCB prototyping manufacturers.

# Chapter 3. The VGA, SD card & audio demo boards for Raspberry Pi Pico and Raspberry Pi Pico W

Figure 12. KiCad 3D rendering of the VGA, SD card & audio design example for Raspberry Pi Pico (top) and Raspberry Pi Pico W (bottom)

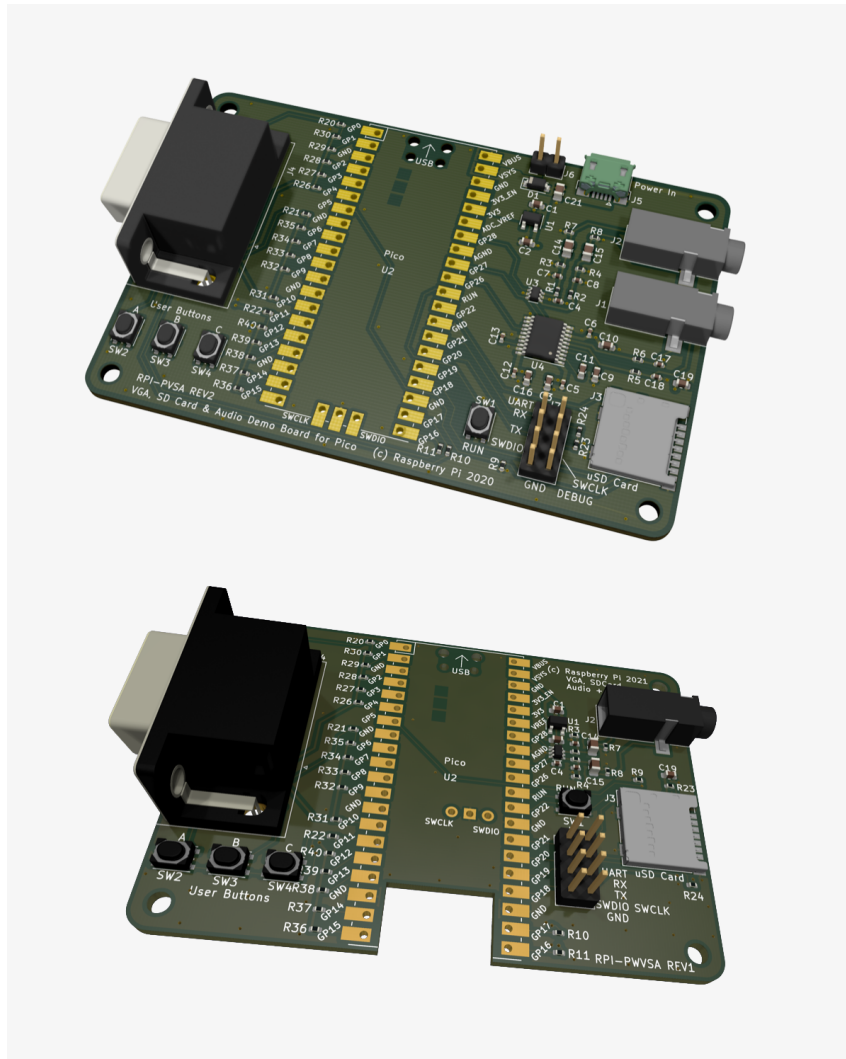

This example design is intended to serve two distinct purposes. Firstly, we show how we can design a PCB that incorporates *Raspberry Pi Pico* or *Raspberry Pi Pico W* as a *module*, used simply as a component on a larger design. Secondly, some of the more complex RP2040 applications require specific additional hardware in order to function correctly. This design provides some example designs for four of these applications, **VGA** video, **SD card** storage, and two flavours of audio output; **analogue PWM**, and **digital I2S** (*Raspberry Pi Pico* only). Experimental software using these features can be found at [Pico Playground](#).

This design is built using *Raspberry Pi Pico* or *Raspberry Pi Pico W*, but as both provide direct access to the pins of RP2040, *much of the circuitry shown here would be equally applicable to designs based around RP2040 itself*.

Schematics and layout files are available for KiCad at <https://datasheets.raspberrypi.com/rp2040/VGA-KiCAD.zip> and <https://datasheets.raspberrypi.com/rp2040/VGA-PicoW-KiCAD.zip>. KiCad is a free, open-source suite of tools for designing PCBs and can be found at <https://kicad.org/>.

One of the key differences between designing with the *Raspberry Pi Pico*/*Raspberry Pi Pico W* and RP2040 is that not all

of the I/Os of RP2040 are available to be used on Raspberry Pi Pico and Raspberry Pi Pico W. This is because some of the I/Os are used for internal house-keeping (such as power supply control and monitoring, and an LED) or the wireless interface on Raspberry Pi Pico W, and are not exposed to the outside world. This introduces some challenges, particularly as our choice of application examples want more pins than are available. We believe we've thought of some cunning solutions to this, especially when you consider that we've also added three user buttons and a UART connection to the mix. We'll go through these constraints, and their solutions, in detail later.

Schematic, PCB layout and Raspberry Pi Pico/Raspberry Pi Pico W footprint files are provided in **KiCad** format, with similar design rules as the previous minimal design example in [Chapter 2](#). This time around, whereas the minimal design example has two layers, with a 1mm thick PCB, we've opted for a four-layer, 1.6mm thick PCB. This is primarily because adding extra layers to our PCB means that we can now devote entire layers to power and ground. This is important in a number of ways. Firstly, it improves power-supply decoupling. With the addition of these two layers, we now have two large, parallel rectangles of copper; one connected to the power supply, the other to ground. These are then separated by a thin dielectric material (an insulating PCB layer sandwiched between the copper layers), which makes this a simple parallel plate decoupling capacitor. Secondly, and perhaps most importantly for this design, we now have a variety of low-impedance paths back to RP2040 where the quickly changing I/O return currents can flow back fast and unhindered, without creating current loops which can cause electromagnetic emissions. Another benefit of moving to four layers is that as there is now less of a gap between signal tracks on the top layer and the ground plane directly beneath, it is now much easier to create tracks of different characteristic impedances that may be required in your designs. In this case, we will want  $75\Omega$  tracks for the VGA colour signals as VGA is a  $75\Omega$  system, using  $75\Omega$  cables and  $75\Omega$  load termination in the monitor.

This design can be sub-divided into five sections: **power**, **VGA**, **SD card**, **audio**, and **Raspberry Pi Pico/Raspberry Pi Pico W itself**.

## 3.1. Power

### 3.1.1. Power input

Figure 13.  
Recommended ways  
of powering Raspberry  
Pi Pico and Raspberry  
Pi Pico W

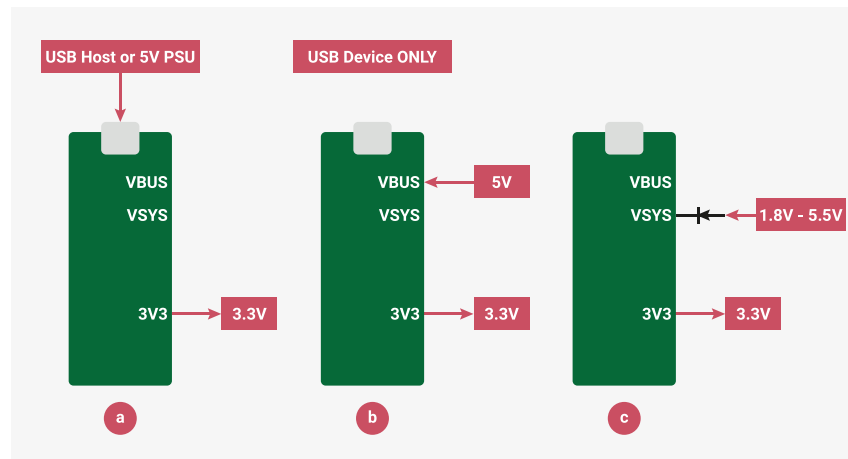

There are three main ways we can safely power Raspberry Pi Pico and Raspberry Pi Pico W, and the choice is entirely dependent on your application. We can either use the **micro USB connector** on the device itself (option (a) in [Figure 13](#)), or we can provide power to either the **VBUS pin** (option b), or the **VSYS pin** (option c).

**NOTE**

The **3.3V** pin is an output from Raspberry Pi Pico or Raspberry Pi Pico W and should not be connected to an external power source. It is intended to be used as an output to provide power to external circuits.

Figure 14. Section of schematic showing power input

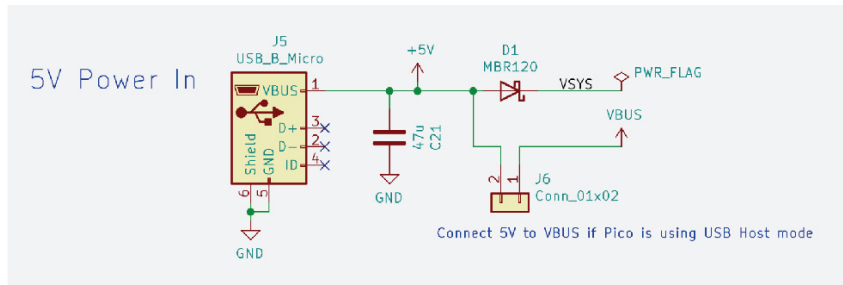

The **VSYS** pin is the main system power supply on Raspberry Pi Pico and Raspberry Pi Pico W. From this supply, a 3.3V supply is generated and used to power RP2040; and also the 3.3V output pin which we can use to power circuits on our design.

The **VBUS** pin is connected to the VBUS of the micro USB connector. There is an onboard diode connecting VBUS to VSYS, which means that VBUS can be used to power VSYS, but not the other way around.

This design provides different options for providing the power, and the *choice of which one to use depends very much on your application*. The first thing to consider is if the USB functionality of Raspberry Pi Pico or Raspberry Pi Pico W will be used.

### 3.1.1.1. Not using USB

If we are not using USB, then we must provide power for Raspberry Pi Pico or Raspberry Pi Pico W. One way of doing this is to *provide power to Raspberry Pi Pico/Raspberry Pi Pico W from our board*, through Raspberry Pi Pico or Raspberry Pi Pico W's pins. See [Figure 15](#) for an illustration of this. The preferred way of implementing this is to provide a voltage to the **VSYS** pin via a Schottky diode ([Figure 14](#)). The one-way nature of the diode ensures we don't encounter any problems if we also supply power to the VBUS pin (accidentally or deliberately). Raspberry Pi Pico and Raspberry Pi Pico W can take a voltage of between 1.8 and 5.5V, as they have an internal buck-boost regulator (one which can regulate the output to a higher or lower voltage than its input), but due to the fact we have an additional voltage regulator in our design (**U1**, more on this later), we need to make sure that VSYS is greater than 3.5V so that **U1** will operate correctly.

Alternatively, we could *provide power to the VBUS pin* (not to be confused with the VBUS connection on Raspberry Pi Pico or Raspberry Pi Pico W's USB connector), rather than the VSYS pin. This would internally power VSYS via the onboard diode, but we must be sure that we *do not connect another power supply to the USB connector* on Raspberry Pi Pico or Raspberry Pi Pico W.

On this design we use a micro USB connector (**J5** in [Figure 14](#)) to provide a 5V power input. This is then connected to VSYS via **D1**, which is an MBR120 Schottky diode that can carry up to 1A. There is also an optional jumper (**J6**) we could use if we need to power the VBUS pin, but as we are not using USB, this is unnecessary.

As a third alternative, we could attach a 5V supply to Raspberry Pi Pico or Raspberry Pi Pico W's USB connector, rather than our board's USB connector, similar to device mode discussed below and in [Figure 16](#).

### 3.1.1.2. Using USB

If we are going to be using USB, then we need to know whether it will be in **host** or **device** mode.

### 3.1.1.2.1. Device mode

If we are using Raspberry Pi Pico or Raspberry Pi Pico W in device mode, then the host it is attached to will provide 5V on the VBUS pin of the USB connector, which in turn will internally provide VSYS with power (5V minus the drop across the onboard diode). This is everything we need, voltage-wise, we do not need to do anything extra on our design; but this power is only available when the USB host is attached. See [Figure 16](#). If we need to be self-powering, i.e. not reliant on the incoming 5V from the USB host, then we need to provide our own power from the carrier board. Again, we can connect a 5V supply to the micro USB connector **J5**, so that we provide around 5V to the **VSYS pin** of Raspberry Pi Pico/Raspberry Pi Pico W. *Make sure jumper **J6** is open circuit*, as this could result in directly connecting two 5V supplies together. See [Figure 15](#) for an illustration.

### 3.1.1.2.2. Host mode

If we are using USB host mode, then this time, Raspberry Pi Pico/Raspberry Pi Pico W needs to provide 5V to the VBUS pin of **its own** micro USB connector (not J5). This means that our carrier board design must supply the **VBUS pin** with 5V, as well as powering Raspberry Pi Pico/Raspberry Pi Pico W. We can do this on our design by simply connecting the micro USB connector (**J5** on the schematic) to a 5V supply, and also by fitting a jumper on **J6**, so that this 5V supply gets connected directly to the VBUS pin of Raspberry Pi Pico/Raspberry Pi Pico W. VSYS is supplied by a combination of the onboard diode on Raspberry Pi Pico and Raspberry Pi Pico W, as well as diode D1 on our design, which is perfectly safe.

Figure 15. Powering the system using the USB power connector on the VGA, SD card & audio board

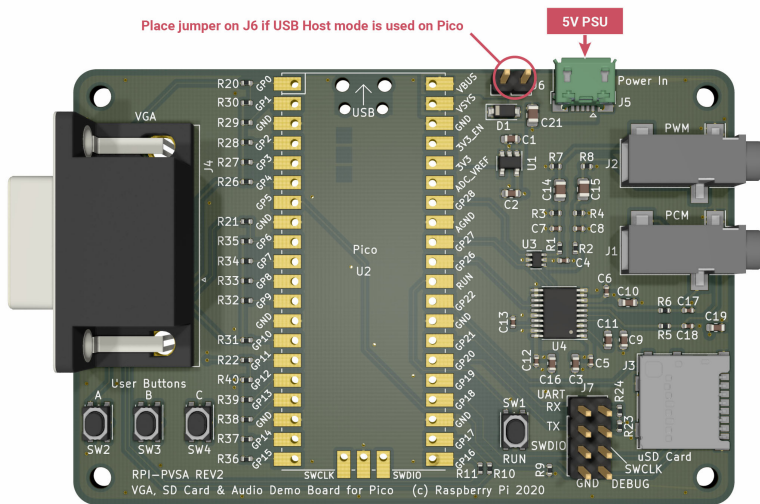
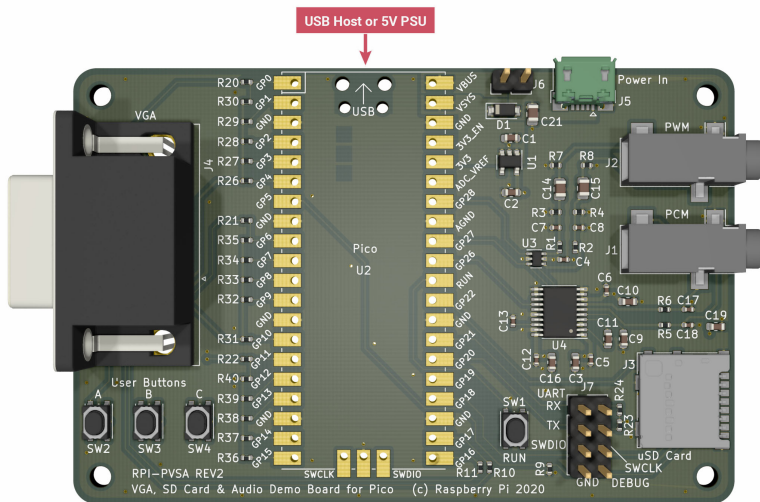
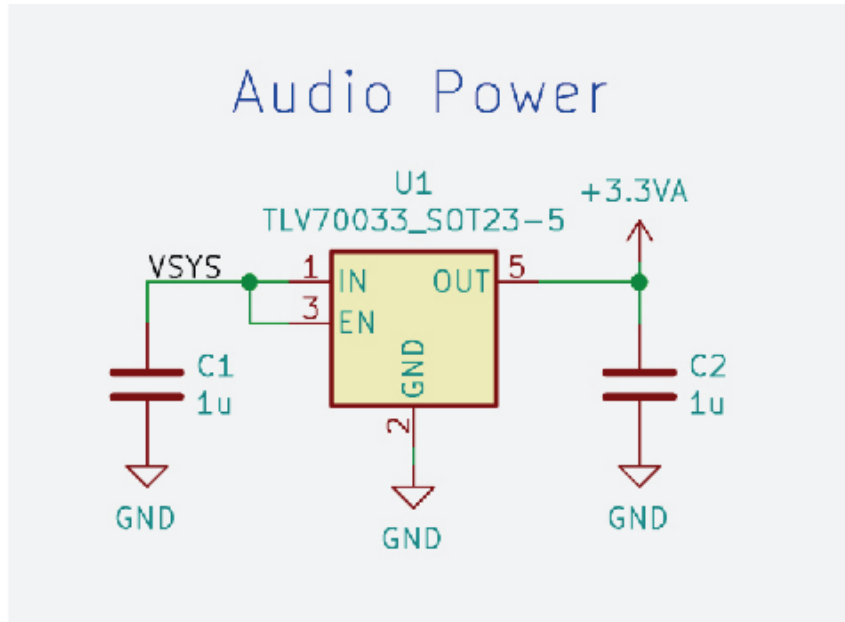

Figure 16. Powering the system using the USB connector on Raspberry Pi Pico/Raspberry Pi Pico W



### 3.1.2. Audio power supply

Figure 17. Schematic section showing an additional LDO used for powering the audio



In addition to providing power for Raspberry Pi Pico and Raspberry Pi Pico W, we have some circuits on this design which need suitable power supplies. Fortunately, they are all 3.3V, so we can simply use the 3.3V supply from Raspberry Pi Pico or Raspberry Pi Pico W itself. However, as we have some audio circuitry on this design, it's good to have a nice, clean power source, without all the digital switching noise, for the sensitive audio output sections. To this end, we've included a 3.3V linear voltage regulator (U1 in Figure 17), specifically for the audio output, which is supplied by VSYS (which is always present, unlike VBUS). This device is a TLV70033, which is a low-dropout (LDO) regulator, with a fixed 3.3V output. This can supply 200mA, which is more than enough for the audio circuits used here. The datasheet for the TLV70033 tells us that we need 1µF capacitors on the input and output pins. We've used 0603 sized ones here (C1 and C2).

#### **i** NOTE

The switching regulator used on Raspberry Pi Pico and Raspberry Pi Pico W has two operating modes, depending on the amount of current running through it. In low-current mode (less than a few tens of mA), in order to increase its efficiency, it starts to run in power saving mode, which uses PFM (pulse frequency modulation). Ordinarily, this is a good thing, as it increases efficiency, reducing the power consumed at low loads. However, this comes at a price: namely a little more voltage ripple on the 3.3V supply. Most of the time this isn't a problem, but for noise-sensitive circuits, you might want to switch this power saving feature off, and return to the less efficient, but less noisy PWM (pulse width modulation) mode. Raspberry Pi Pico and Raspberry Pi Pico W allow us to do this by forcing the regulator to always use PWM mode, and we do this by setting GPIO23 on RP2040 high. In the VGA demo below, the effects of this noise can be seen if we look carefully at the VGA monitor; we can see slight variations of colour in the horizontal lines, as this supply noise is transferred directly to the DAC outputs. If we disable the PFM mode of the regulator, this magically goes away.

## 3.2. VGA video



Figure 18. Schematic section showing the VGA video connector

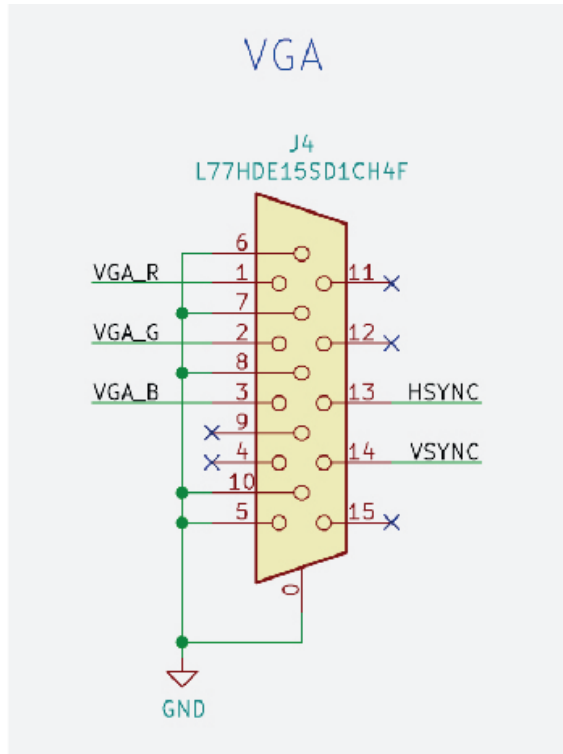

The first application of RP2040 we're demonstrating is VGA analogue video output. This particular example uses the PIO (programmable I/O) on RP2040 to output a commonly used 16-bit RGB data format (RGB-565), and these digital outputs then need to be converted to three analogue output signals: one for each colour. RGB-565 uses five bits each for the red and blue channels, and six bits for the green. In addition to these 16 data bits, VGA monitors also require HSYNC and VSYNC signals for horizontal and vertical blanking timing. That brings us to a total of 18 pins that are needed. As we've mentioned before, pins are at a premium, and we want to use as few as possible so that we can cram more functionality into this design. To this end, we can free up a pin by limiting the green channel to five bits, which will make all the channels the same resolution, by removing the green LSB (least significant bit). It is still desirable for RP2040 to process RGB-565 format data, so PIO will still output six bits of green data to the GPIOs; but we can choose not to use the green LSB in the function select register of that particular GPIO, instead letting RP2040 use it for something else (in this case, the clock for the SD card). The VGA PIO software requires that all 16 bits of data need to be on contiguous (in unbroken, consecutive numerical order) GPIOs, with the sequence being red first, then green, then blue, with the LSB first in each case, which introduces a further design constraint. Raspberry Pi Pico and Raspberry Pi Pico W each have two contiguous rows of GPIOs available for our use: GPIOs 0 to 22, and 26 to 28. We therefore must place VGA data somewhere in 0 to 22, and it makes sense to start at one end or the other in order to make sure there are as many contiguous pins remaining for other functions as possible. We've chosen to use GPIO 0 to 15, which means that the green LSB is GPIO 5, and this is going to be used as SD\_CLK. HSYNC and VSYNC can go on any GPIO, as long as they are next to each other. We've picked 16 and 17.

### 3.2.1. Resistor DAC



Figure 19. Schematic section showing the red channel of the VGA resistor DAC

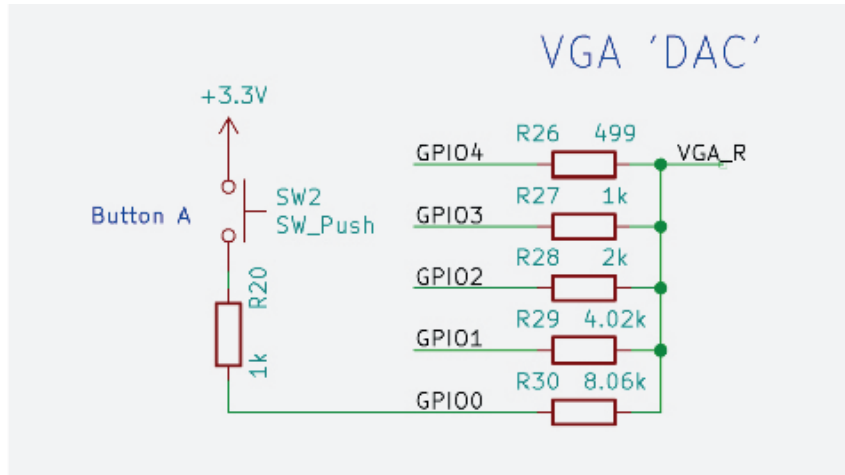

The three colour channels on a VGA connector need to be analogue signals, varying from 0 to 0.7V. We therefore need to convert the digital, 3.3V outputs of RP2040 to an analogue signal. Dedicated video DACs (digital to analogue converters) can be used to do this, but a cheaper and simpler method is shown here. You can create a simple DAC using a group of resistors connected directly to the digital outputs. The values of the resistors are weighted to give different amounts of significance to each bit, in the ratio 1:2:4:8:16. It's not going to be as good as using a dedicated video DAC - one of the major drawbacks is that any voltage variation on the IOVDD supply of RP2040 is going to be present on the DAC output - but it's cheaper, considerably less complex, and a lot more fun. If we look at the red channel, net VGA\_R on the schematic, we can see the red LSB (GPIO0) is connected to it through a 8.06kΩ resistor. The next bit (GPIO1) has (roughly) half this (4.02kΩ), the next has half again, and so on for the rest of the bits. Ideally, for the most linear DAC performance, we want exactly double the previous resistor value, but these are the nearest commonly available 1% values. This means each GPIO output bit can contribute twice as much current through its resistor than the previous bit, and all these individual current contributions are summed together at the output. The result of this is that if all the bits are high (3.3V), corresponding with the maximum digital value, we have all five resistors in parallel to 3.3V. Basic circuit theory tells us that this is  $1/R_{\text{parallel}} = 1/499 + 1/1000 + 1/2000 + 1/4020 + 1/8060 = 0.00388$ , so  $R_{\text{parallel}}$  is 258Ω. If we have a monitor connected to this signal, then we will have a 75Ω resistor to ground inside the monitor (this isn't shown on this schematic). This creates a potential divider, with 3.3V connected to 258Ω, which in turn is then connected to 75Ω to ground in the monitor. This means we have a full-scale voltage of  $3.3 \times 75 / (258 + 75) = 0.74V$ , which is close enough to the target of 0.7V.

### 3.2.2. User buttons

The user buttons are not strictly part of the VGA, but because we've decided to add them (**SW2**, **SW3** and **SW4**, see [Figure 19](#)), connecting them to the LSBs of the red, green and blue channels, it's important to talk about them, and on their use in the software. We thought it was important to add a few buttons to this design, especially as VGA, SD card and audio give us a lot of potential applications that could use a button or two (e.g. video or music controls, etc). As we've already said, pins are at a premium, and we couldn't afford to dedicate a pin or two to something as frivolous as buttons, so we've come up with the idea of making the VGA LSBs multi-purpose, with a simple hack.

The basic idea is that the GPIO in question is used for VGA as usual during the active periods of video data, but during the video blanking periods, when the DAC levels are not as critical, we can flip the GPIO direction to an input, and then poll it, before flipping it back to an output for the next active video period. If button **SW2** is pressed, then GPIO0 will be connected to potential divider of a 1kΩ resistor (**R20**) to 3.3V, and 8.06kΩ (**R30**) to (worst-case) 0V. This means that GPIO0 will see at least 2.93V, and will therefore register as logic 1. If the button is not depressed, then GPIO4 will be 0.7V or lower, which will result in a logic 0. Of course, this relies on a monitor's 75Ω load resistor for the pull-down. If there is no monitor present, then the user could activate the GPIO's internal pull-down instead.

Obviously, if the button is pressed during active video transmission, then we might expect this to have an effect on the DAC signal level. However, as we are only interfering with the LSB, any effect would be minimal, but the introduction of the 1kΩ resistor (**R20**) in series with the button means that RP2040 will have little problem over-driving this, so the effect on the DAC signal will be minimal. The final point to note regarding the DAC is that, as we've previously

mentioned, the outputs should have 75Ω characteristic impedance. On this PCB, we've used a 1.6mm, four-layer board stack-up, with a gap of 0.36mm between the outer and inner layers. This means that track widths of 0.3mm gives us roughly 75Ω.

### 3.3. SD card

Figure 20. Schematic section showing the micro SD card connector

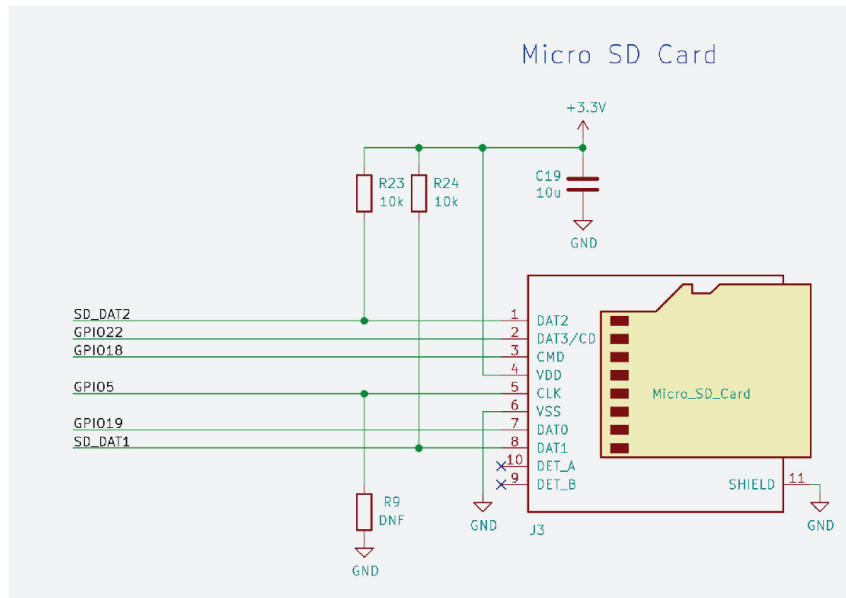

The second application we are demonstrating is using an SD card. This design has a micro SD card (**J3**), which has a 4-bit data bus, as well as a clock (CLK) and command (CMD) signal. We can access the SD card in either 4-bit mode, SPI, or 1-bit mode. The constraints our SD PIO software puts upon us is that the four data signals must be connected to contiguous GPIOs. The CLK and CMD signals can go anywhere. As the VGA signals have used up GPIOs 0 to 17, we are left with a contiguous block of five GPIOs, 18 to 22. We will use GPIO19 to 22 for the data bus, and GPIO18 for the CMD signal. For the CLK signal, we are going to use GPIO5, which is in the middle of the VGA signals. If you remember, GPIO5 was earmarked for the 6th, unused bit of the green VGA output. This GPIO can be repurposed by selecting a different function on the GPIO mux, so we are free to assign it to be SD CLK. Often, SD interfaces include pull-up and pull-down resistors on the PCB. This is to ensure that safe values are present at all times, especially when the I/Os are in an undefined state; but also because some of the SD signals are used as mode-select pins (e.g. SPI mode, 1-bit mode, etc). In this design, we are relying on RP2040 to set the GPIO pulls. We have added the option for a pull-down for the CLK signal (**R9**) should we find that in a particular application it is needed, as it is important the CLK input is in a valid state at all times. Having said all this, we have actually included pull-ups on bits 1 and 2 of the SD data bus (**R23 & R24**). This is because we haven't wired these SD card I/Os directly to Raspberry Pi Pico, and have instead connected them via jumper headers (pins 1 to 2 and 3 to 4 of **J7**), which means it's possible to remove the jumpers and still have valid levels on these I/Os. Obviously, if we want 4-bit operation, we must connect the jumpers first. The reason we've done this is, as has been already mentioned, the SD card can also be accessed using SPI or 1-bit mode, which means that if either of these methods are used, we can potentially repurpose data bits 1 and 2 for other uses. Which brings us to...

#### 3.3.1. UART

Figure 21. Schematic section showing the optional UART and SWD debug header

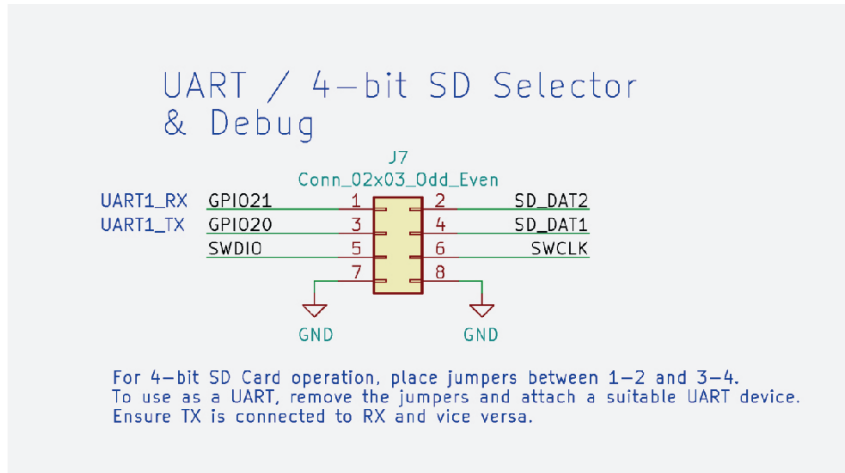

As alluded to above, if we use the SD card in 1-bit mode, or do not even use SD card at all, we are then free to use these pins for a UART, which is always a useful thing to have. To this end, we can simply connect a 3.3V compatible UART to pins 1 and 3 of **J7**, rather than the jumpers needed for 4-bit SD card operation. Nominally, GPIO21 is UART1\_RX, and GPIO20 is UART1\_TX if the dedicated hardware UART controllers are used, but if a PIO UART is implemented, then the TX and RX selection would be configurable.

### 3.3.2. Debug – SWD

**J7** is also home to the SWDIO and SWCLK pins on this design. If Raspberry Pi Pico or Raspberry Pi Pico W has been attached to this PCB in such a way as to connect the debug pins, then they are made available on this header to connect a debugger to. Of course, a debugger could also be connected directly to the Raspberry Pi Pico/Raspberry Pi Pico W itself if this is more suitable.

## 3.4. Audio

This design demonstrates two different audio options that RP2040 can use, analogue PWM and digital PCM/I2S. However, as you might expect, we cannot afford to dedicate separate pins for each solution, so these two options use the same pins, and the choice of which is to be used is made in software. The circuitry for both audio options have been populated, as the option not being used shouldn't suffer any problems when driven in the wrong mode.

### **i** NOTE

We need to remember to connect the audio output device to the correct jack: **J1** for PCM and **J2** for PWM.

These outputs are intended to be used as a line-level driver, and connected to an amplifier's line-in input, but they should also work for headphones with higher impedances. The remaining GPIOs we have available are 26 to 28, and happily, this is all that is needed; two for PWM, and three for PCM.

### 3.4.1. PWM audio

Figure 22. Schematic section showing the Analogue PWM audio circuit

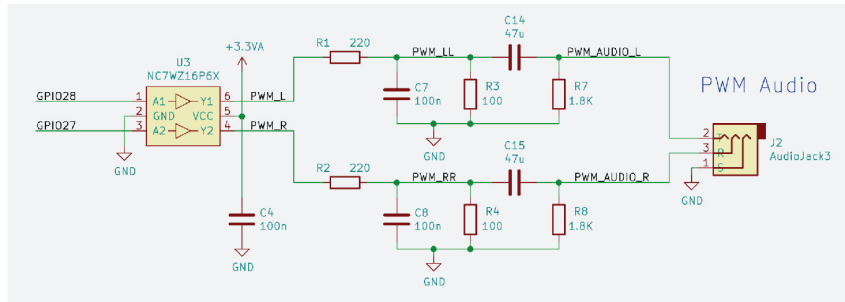

The first method we are going to consider is the analogue PWM. This method is the same as is used on the Raspberry Pi 4 audio output jack, and we've borrowed the circuit from it. This works by taking the digital audio, and outputting it from two GPIO pins as digital PWM (pulse width modulation) signals, one for each of the stereo pair. These digital signals are then fed into a small logic buffer (U3). This is so that we can use our nice, clean, audio 3.3V supply we discussed earlier, so hopefully we won't get the digital noise from the main 3.3V supply on our audio signal. This buffered output, which is still a 3.3V digital signal, is then fed into an analogue filter, and the result is that we get an AC-coupled analogue signal in the audible frequency range, which we can then connect to an amp or headphones.

### 3.4.2. PCM/I2S audio

**NOTE**

I2S audio output isn't included in the VGA, SD card & audio design example for Raspberry Pi Pico W

Figure 23. Schematic section showing the Digital I2S PCM audio circuit

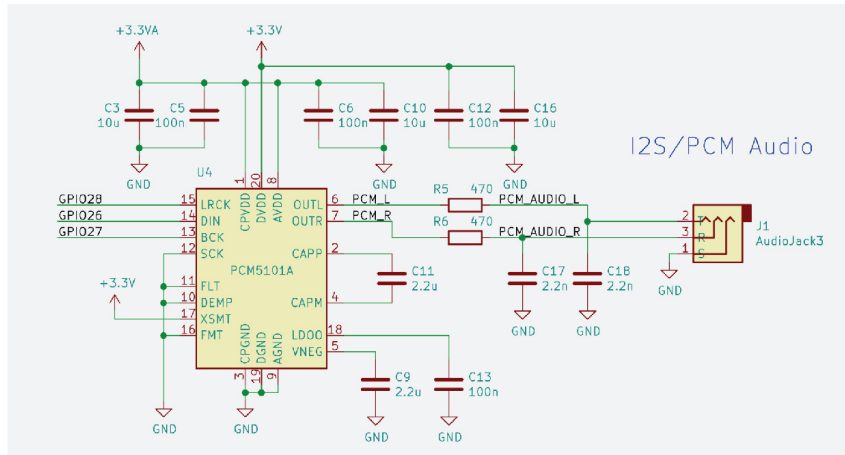

The second audio option used here is digital PCM using I2S. This method takes digital audio in PCM (pulse code modulation) format, and sends it using the I2S protocol to an audio DAC, which in turn is connected to an audio output jack. In this design, we've chosen to use the PCM5101A audio DAC. GPIO27 is connected to the BCK input (bit clock), GPIO26 to DIN (serial data), and GPIO28 to LRCK (left or right clock). The rest of the circuitry surrounding the DAC is as per the typical application circuit in the PCM5101A datasheet.

## 3.5. Raspberry Pi Pico and Raspberry Pi Pico W

Figure 24. Schematic section showing the connections to Raspberry Pi Pico

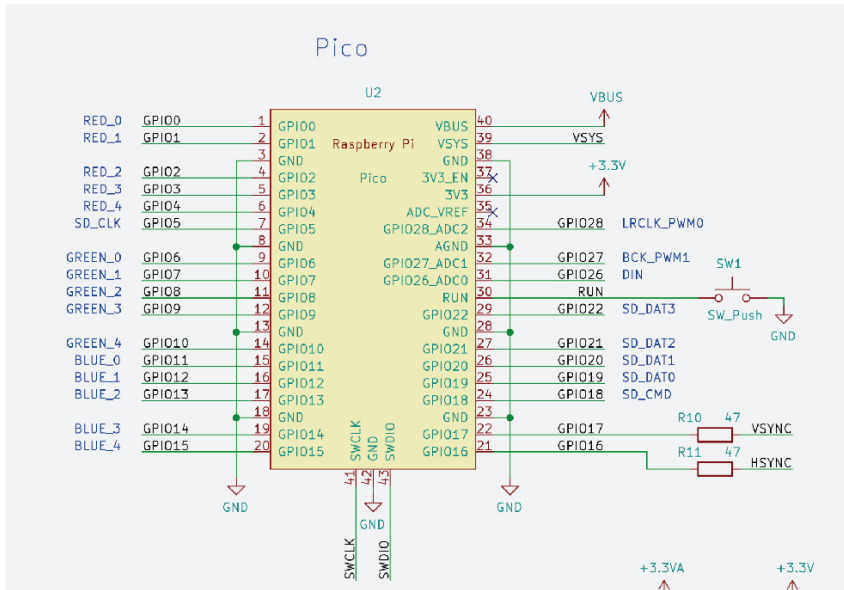

The final piece of the design is the Raspberry Pi Pico or Raspberry Pi Pico W itself.

**NOTE**

All the pins of Raspberry Pi Pico W are identical to those of Raspberry Pi Pico. The only external difference between the two devices is the debug connector, which has moved to make space for the onboard antenna on Raspberry Pi Pico W.

We have already covered the vast majority of the connections in the preceding sections; however, there are a few pins we haven't covered. We've already discussed how the power pins are to be connected (VBUS and VSYS inputs and 3.3V output), but as yet we haven't really mentioned **GND**. All of the GND pins should be connected to ground net on our board, and ideally to a low impedance ground plane to minimise noise and EMC emissions. There is an **AGND** pin on Raspberry Pi Pico and Raspberry Pi Pico W, which is intended to be used as a low noise ADC return path. As we are not using the ADC in this application, we simply connect this to regular GND. There is also an **ADC\_VREF** pin, which can be optionally used to supply a clean and stable reference as an alternative to the Raspberry Pi Pico onboard 3.3V supply, but again, as we are not using the ADC, we can safely leave this pin floating. The **RUN** pin on Raspberry Pi Pico is the reset\_n (active low) for RP2040. It is pulled high (i.e. the RP2040 is running) on Raspberry Pi Pico, but with the addition of a push button (**SW1**) we can pull this pin low, causing RP2040 to reset. The final pin on Raspberry Pi Pico is **3V3\_EN**, which controls the 3.3V supply on Raspberry Pi Pico. As we have no need to disable this supply on this board, we can leave this pin floating as there is a pull-up on Raspberry Pi Pico itself.

And finally, to perhaps the most important part of this design, how do we attach the Raspberry Pi Pico or Raspberry Pi Pico W itself? There are two choices, and this design lets us pick either.

Figure 25. Close-up of surface-mount and through-hole pad

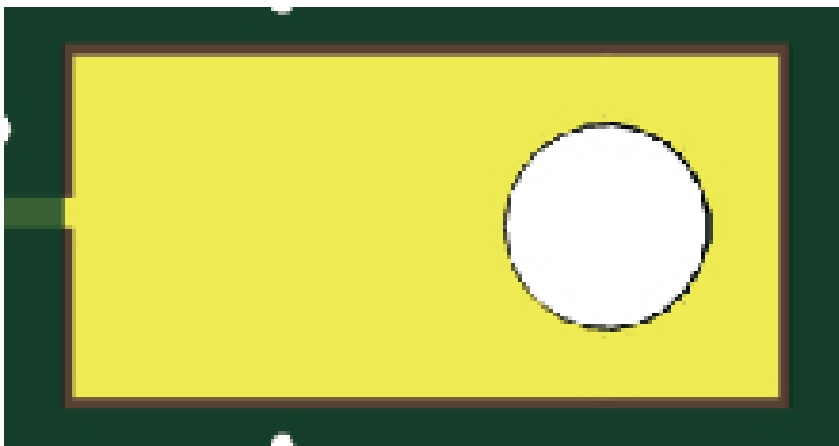

Each pin on Raspberry Pi Pico and Raspberry Pi Pico W has two soldering options. You can either solder 0.1" headers using the through-holes, or alternatively, as both have castellated edges (where the pin extends to the edge of the board, and then down the edge of the PCB itself), a pin can be soldered down directly to a PCB. If the SWD pins are used then they should have an extra pin added to ensure a good connection.

Figure 26. Surface-mount and through-hole footprint for attaching to Raspberry Pi Pico

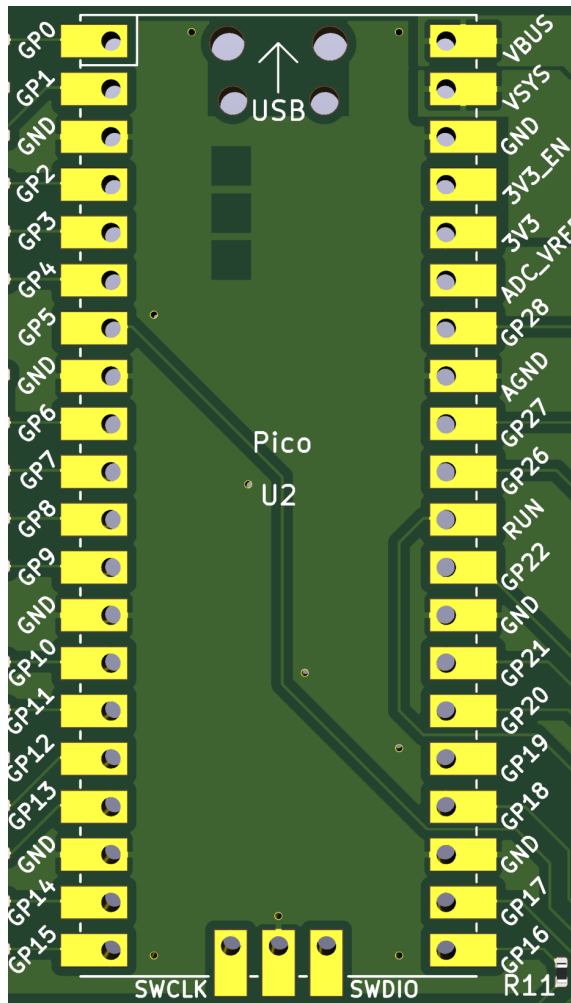
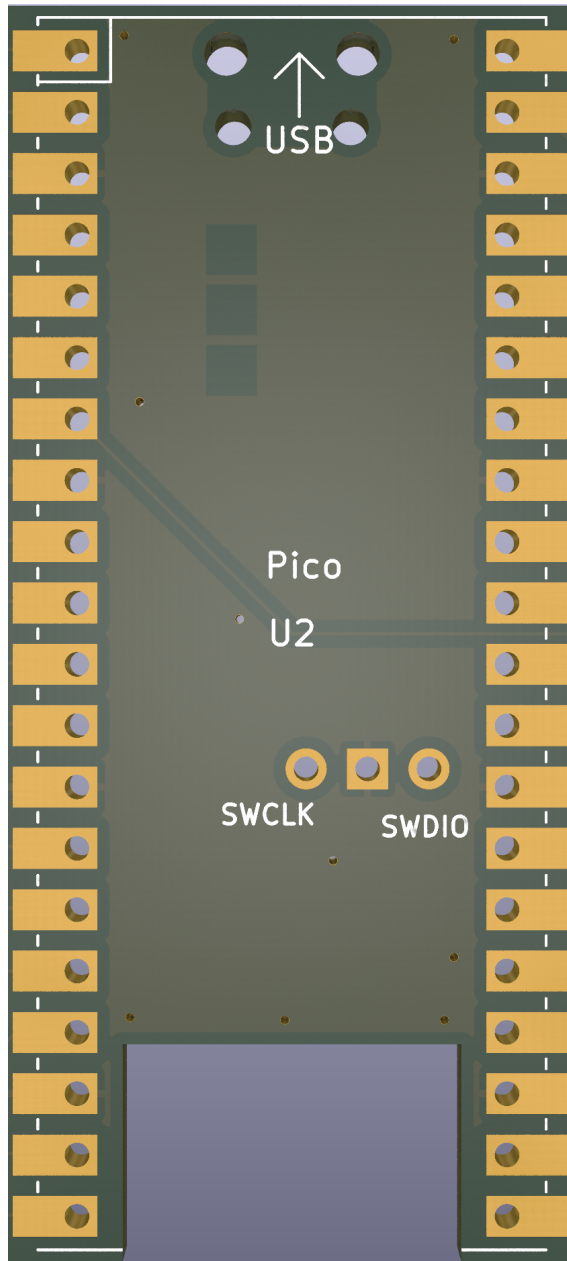

Figure 27. Surface-mount and through-hole footprint for attaching to Raspberry Pi Pico W



The CAD footprint provided with this design provides both options, so Raspberry Pi Pico or Raspberry Pi Pico W can either be soldered direct to this design, or 0.1" headers may be used (or indeed, a combination of 0.1" headers and sockets) to connect the two PCBs together.

**NOTE**

In Raspberry Pi Pico W there is a cutout for the antenna (14mm × 9mm). If anything is placed close to the antenna (in any dimension) the effectiveness of the antenna is reduced. Raspberry Pi Pico W should be placed on the edge of a board and not enclosed in metal to avoid creating a Faraday cage. Adding ground to the sides of the antenna improves the performance slightly.

Figure 28. Holes and copper keepout areas under the USB connector and testpoints on Raspberry Pi Pico and Raspberry Pi Pico W

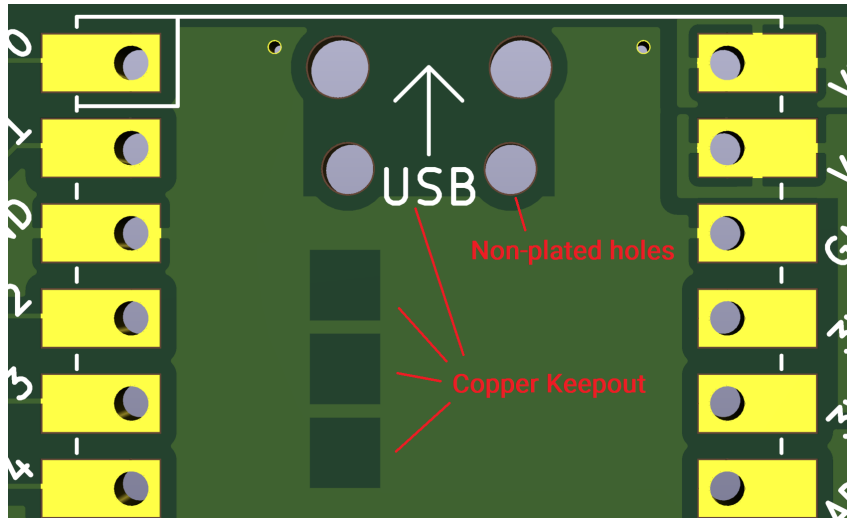

Another feature of this footprint are the four drill holes visible towards the top of the board, directly underneath the micro USB connector (see [Figure 28](#)). These are here to help the Raspberry Pi Pico or Raspberry Pi Pico W sit flat against our carrier PCB, as the metal through-hole lugs which anchor the USB connector can sometimes protrude slightly from the board. These holes allow any excess metal or solder to safely poke through. As well as these holes, you can see some areas of keepout on the top copper layer. This is because the undersides of Raspberry Pi Pico and Raspberry Pi Pico W have some testpoints, which are exposed areas of copper that get used during production testing, and these keepouts align with the testpoints. This is not strictly necessary, as there is still solder resist (the green insulating material on the surfaces of the PCB) on our PCB, but we consider it good practice to do so as it makes the chances of shorting these testpoints through accidental damage, or poor PCB fabrication, almost zero. Of course, this only applies if Raspberry Pi Pico/Raspberry Pi Pico W is soldered directly to our board. If you want to use headers to attach Raspberry Pi Pico/Raspberry Pi Pico W, then these copper keepouts, and also the USB holes, are unnecessary and can be removed.

#### **i** NOTE

KiCad currently doesn't have a keepout layer in its footprints. The recommended approach, and the one we've used here, is to show the keepout zones on the `dwgs.user` layer, and the user must then manually remove the copper on the PCB layout itself.

This brings us to the topic of component keepouts. Obviously, if you will be directly soldering Raspberry Pi Pico or Raspberry Pi Pico W to your board, then the entire footprint will have to have a component keepout underneath. If you are only ever going to attach Raspberry Pi Pico/Raspberry Pi Pico W with sockets and/or headers, then you are free to place components beneath it (provided you keep them a sensible distance from the header/sockets themselves). You must make sure that the height of any components added underneath are less than the gap needed by the socket or header used.

## 3.6. Schematics

The final part of this guide is the schematics themselves. As mentioned in the introduction to this guide, the actual KiCad schematic files are available, and you are encouraged to go and check them out, particularly as the schematic drawings shown below could very well now be outdated.



Figure 29. The complete schematic of the VGA, SD card & audio design example for Raspberry Pi Pico

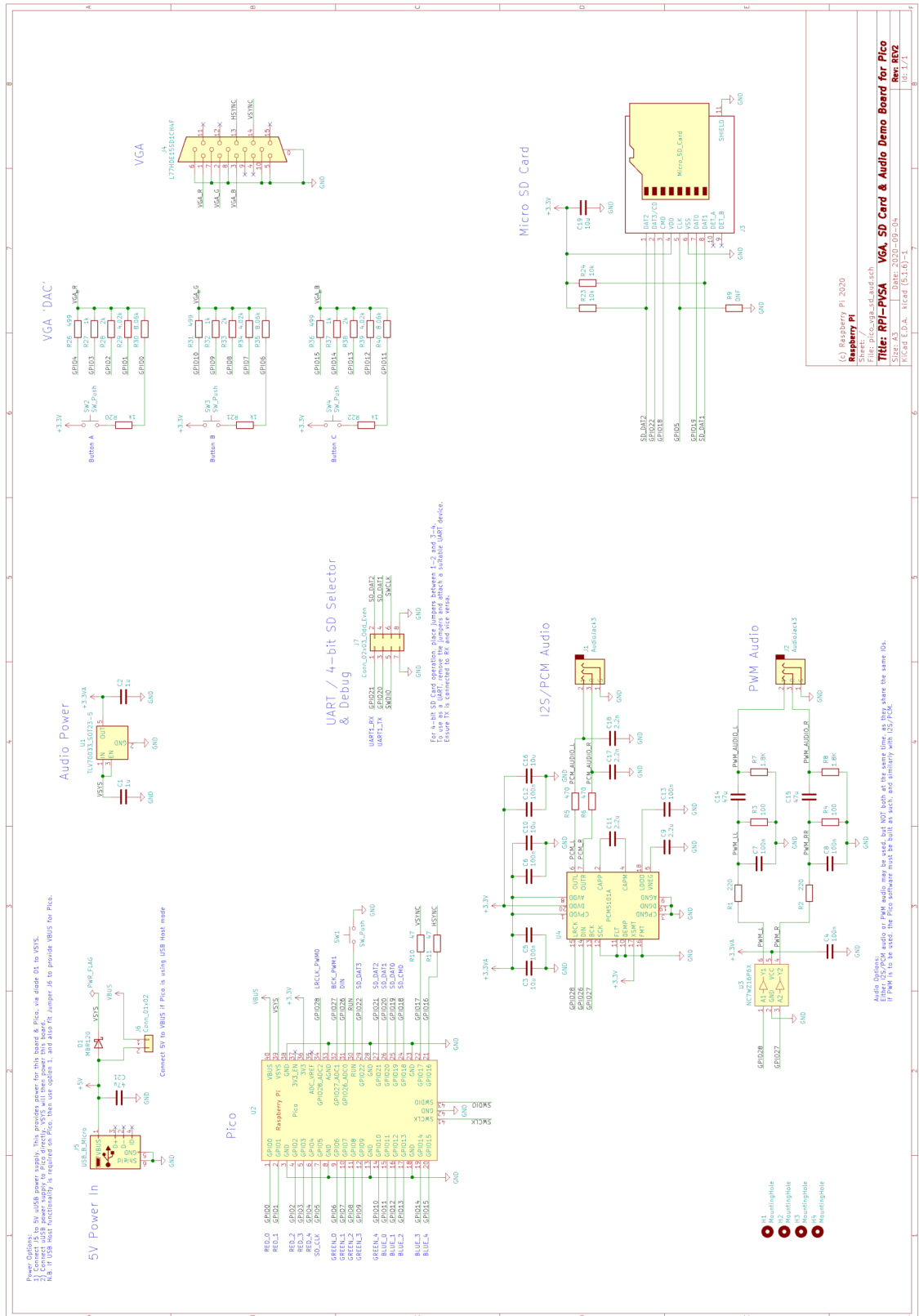
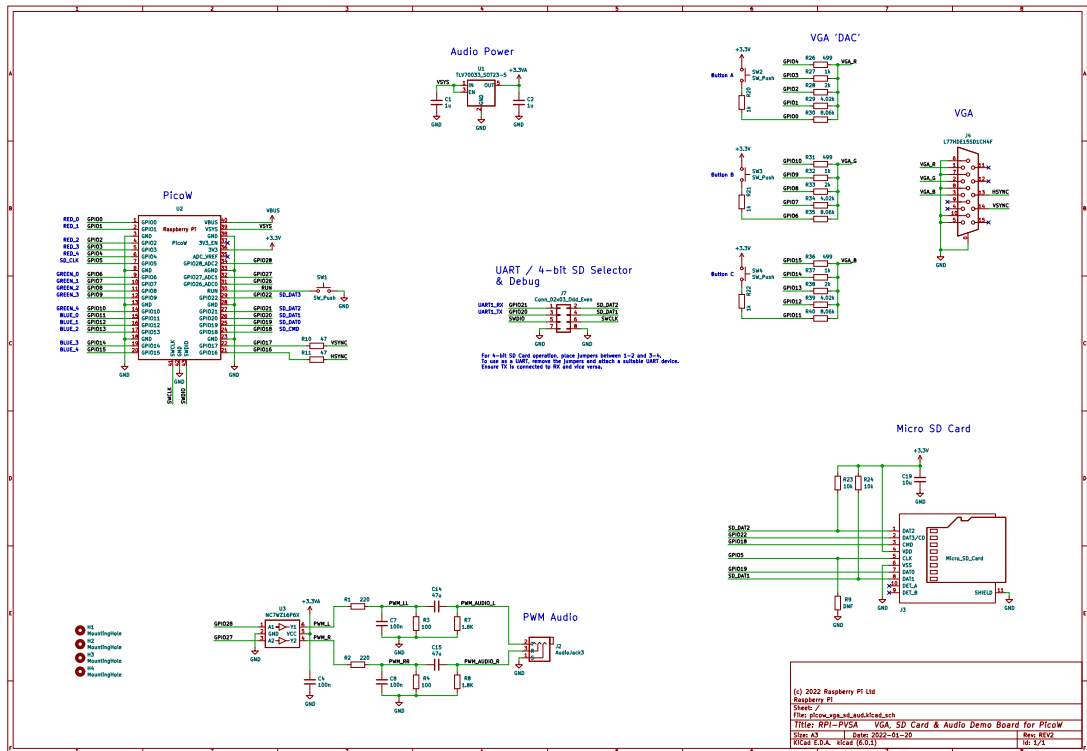

Figure 30. The complete schematic of the VGA, SD card & audio design example for Raspberry Pi Pico W



# Appendix A: Using the rescue debug port

## Overview

The rescue debug port (DP) on RP2040 can be used to reset the chip into a known state if the user has programmed some bad code into the flash. For example some code that turned off the system clock would stop the processor debug ports being accessed, but the rescue DP would still work because it is clocked from the `SWCLK` of the SWD interface.

On the Raspberry Pi Pico, the BOOTSEL button can be used to force the chip into BOOTSEL mode instead of executing the code in flash. The rescue DP is intended for use in designs that use an RP2040 but don't have a BOOTSEL button.

### **i** NOTE

For further information on how to configure SWD see the [Getting started with Raspberry Pi Pico](#) book.

## Activating the rescue DP from OpenOCD

The RP2040 port of OpenOCD provides two targets:

- `rp2040.cfg`
- `rp2040-rescue.cfg`

`rp2040-rescue.cfg` connects to the rescue debug port with id `0xf`.

To use the rescue DP, start OpenOCD with the `rp2040-rescue` configuration.

```
$ openocd -f interface/raspberrypi-swd.cfg -f target/rp2040-rescue.cfg
...
Warn : gdb services need one or more targets defined
Now attach a debugger to your RP2040 and load some code
Info : Listening on port 6666 for tcl connections
Info : Listening on port 4444 for telnet connections

Ctrl + C
```

Now start OpenOCD with the normal `rp2040` configuration.

```
$ openocd -f interface/raspberrypi-swd.cfg -f target/rp2040.cfg
```

To verify the rescue DP restarted the chip, you can check the `VREG_AND_POR.CHIP_RESET` register: `0x40064008`. Bit 20 of this register is the `HAD_PSM_RESTART` bit.

In another terminal connect to the OpenOCD telnet port and use `mdw` (memory display word) to read the `CHIP_RESET` register. If the rescue DP restarted the chip, then the value will be `0x00100000`, aka bit 20 will be set.

```
$ telnet 127.0.0.1 4444
Trying 127.0.0.1...
Connected to 127.0.0.1.
Escape character is '^]'.
Open On-Chip Debugger
> mdw 0x40064008
0x40064008: 00100000
```

You can now load code as described in [Use GDB and OpenOCD to debug Hello World](#) in [Getting started with Raspberry Pi Pico](#) book.

# Appendix B: Documentation release history

Table 2.  
Documentation  
release history

Release	Date	Description
1.0	21 Jan 2021	<ul style="list-style-type: none"> <li>Initial release</li> </ul>
1.1	26 Jan 2021	<ul style="list-style-type: none"> <li>Minor corrections</li> <li>Extra information about using DMA with ADC</li> <li>Clarified M0+ and SIO CPUID registers</li> <li>Added more discussion of Timers</li> <li>Update Windows and macOS build instructions</li> <li>Renamed books and optimised size of output PDFs</li> </ul>
1.2	01 Feb 2021	<ul style="list-style-type: none"> <li>Minor corrections</li> <li>Small improvements to PIO documentation</li> <li>Added missing TIMER2 and TIMER3 registers to DMA</li> <li>Explained how to get MicroPython REPL on UART</li> <li>To accompany the V1.0.1 release of the C SDK</li> </ul>
1.3	23 Feb 2021	<ul style="list-style-type: none"> <li>Minor corrections</li> <li>Changed font</li> <li>Additional documentation on sink/source limits for RP2040</li> <li>Major improvements to SWD documentation</li> <li>Updated MicroPython build instructions</li> <li>MicroPython UART example code</li> <li>Updated Thonny instructions</li> <li>Updated Project Generator instructions</li> <li>Added a FAQ document</li> <li>Added errata <a href="#">E7</a>, <a href="#">E8</a> and <a href="#">E9</a></li> </ul>
1.3.1	05 Mar 2021	<ul style="list-style-type: none"> <li>Minor corrections</li> <li>To accompany the V1.1.0 release of the C SDK</li> <li>Improved MicroPython UART example</li> <li>Improved Pinout diagram</li> </ul>
1.4	07 Apr 2021	<ul style="list-style-type: none"> <li>Minor corrections</li> <li>Added errata <a href="#">E10</a></li> <li>Note about how to update the C SDK from Github</li> <li>To accompany the V1.1.2 release of the C SDK</li> </ul>

Release	Date	Description
1.4.1	13 Apr 2021	<ul style="list-style-type: none"> <li>• Minor corrections</li> <li>• Clarified that all source code in the documentation is under the <a href="#">3-Clause BSD</a> license.</li> </ul>
1.5	07 Jun 2021	<ul style="list-style-type: none"> <li>• Minor updates and corrections</li> <li>• Updated FAQ</li> <li>• Added SDK release history</li> <li>• To accompany the V1.2.0 release of the C SDK</li> </ul>
1.6	23 Jun 2021	<ul style="list-style-type: none"> <li>• Minor updates and corrections</li> <li>• ADC information updated</li> <li>• Added errata <a href="#">E11</a></li> </ul>
1.6.1	30 Sep 2021	<ul style="list-style-type: none"> <li>• Minor updates and corrections</li> <li>• Information about B2 release</li> <li>• Updated errata for B2 release</li> </ul>
1.7	03 Nov 2021	<ul style="list-style-type: none"> <li>• Minor updates and corrections</li> <li>• Fixed some register access types and descriptions</li> <li>• Added core 1 launch sequence info</li> <li>• Described SDK "panic" handling</li> <li>• Updated picotool documentation</li> <li>• Additional examples added to <b>Appendix A: App Notes</b> appendix in the <a href="#">Raspberry Pi Pico C/C++ SDK</a> book</li> <li>• To accompany the V1.3.0 release of the C SDK</li> </ul>
1.7.1	04 Nov 2021	<ul style="list-style-type: none"> <li>• Minor updates and corrections</li> <li>• Better documentation of USB double buffering</li> <li>• Picoprobe branch changes</li> <li>• Updated links to documentation</li> </ul>
1.8	17 Jun 2022	<ul style="list-style-type: none"> <li>• Minor updates and corrections</li> <li>• Updated setup instructions for Windows in <a href="#">Getting started with Raspberry Pi Pico</a></li> <li>• Additional explanation of SDK configuration</li> <li>• RP2040 now qualified to -40°C, minimum operating temperature changed from -20°C to -40°C</li> <li>• Increased PLL min VCO from 400MHz to 750MHz for improved stability across operating conditions</li> <li>• Added reflow-soldering temperature profile</li> <li>• Added errata <a href="#">E12</a>, <a href="#">E13</a> and <a href="#">E14</a></li> <li>• To accompany the V1.3.1 release of the C SDK</li> </ul>

Release	Date	Description
1.9	30 Jun 2022	<ul style="list-style-type: none"> <li>• Minor updates and corrections</li> <li>• Update to VGA board hardware description for launch of Raspberry Pi Pico W</li> <li>• To accompany the V1.4.0 release of the C SDK</li> </ul>
Pico and Pico W databooks combined into a unified release history		
2.0	01 Dec 2022	<ul style="list-style-type: none"> <li>• Minor updates and corrections</li> <li>• Added RP2040 availability information</li> <li>• Added RP2040 storage conditions and thermal characteristics</li> <li>• Replace SDK library documentation with links to the online version</li> <li>• Updated Picoprobe build and usage instructions</li> </ul>
2.1	03 Mar 2023	<ul style="list-style-type: none"> <li>• A large number of minor updates and corrections</li> <li>• SMT footprint of Pico W corrected</li> <li>• Updated for the 1.5.0 release of the Raspberry Pi Pico C SDK</li> <li>• Added errata <a href="#">E15</a></li> <li>• Added documentation around the new <a href="#">Pico Windows Installer</a></li> <li>• Added documentation around the <a href="#">Pico-W-Go</a> extension for Python development</li> <li>• Added a wireless networking example to the Python documentation</li> <li>• Added package marking specifications</li> <li>• Added RP2040 baseline power consumption figures</li> <li>• Added antenna keep out diagram to Pico W datasheet</li> </ul>
2.2	14 Jun 2023	<ul style="list-style-type: none"> <li>• Minor updates and corrections</li> <li>• Updated for the 1.5.1 release of the Raspberry Pi Pico C SDK</li> <li>• Documentation around Bluetooth support for Pico W</li> </ul>
2.3	02 Feb 2024	<ul style="list-style-type: none"> <li>• Numerous minor updates and corrections</li> <li>• Update ROSC register information</li> <li>• Updated getting started documentation for MS Windows and Apple macOS</li> <li>• Updates arising from the release of Raspberry Pi 5</li> <li>• Reintroduced updated SDK library documentation (was withdrawn in 2.0 due to XML conflicts)</li> <li>• Updated to include the new recommended part number for crystals used with RP2040</li> <li>• Added new paste stencil information for Pico and Pico W</li> <li>• Other updates to supporting documentation</li> </ul>

The latest release can be found at <https://datasheets.raspberrypi.com/rp2040/hardware-design-with-rp2040.pdf>.